

PUBLIC

**HITACHI**  
Inspire the Next

# Large scale RES integration by HVDC

Staying ahead - Next Phase

2023-09-26

© 2023 Hitachi Energy. All rights reserved.

 **Hitachi Energy**

# HVDC applications - Shaping the grids of the future

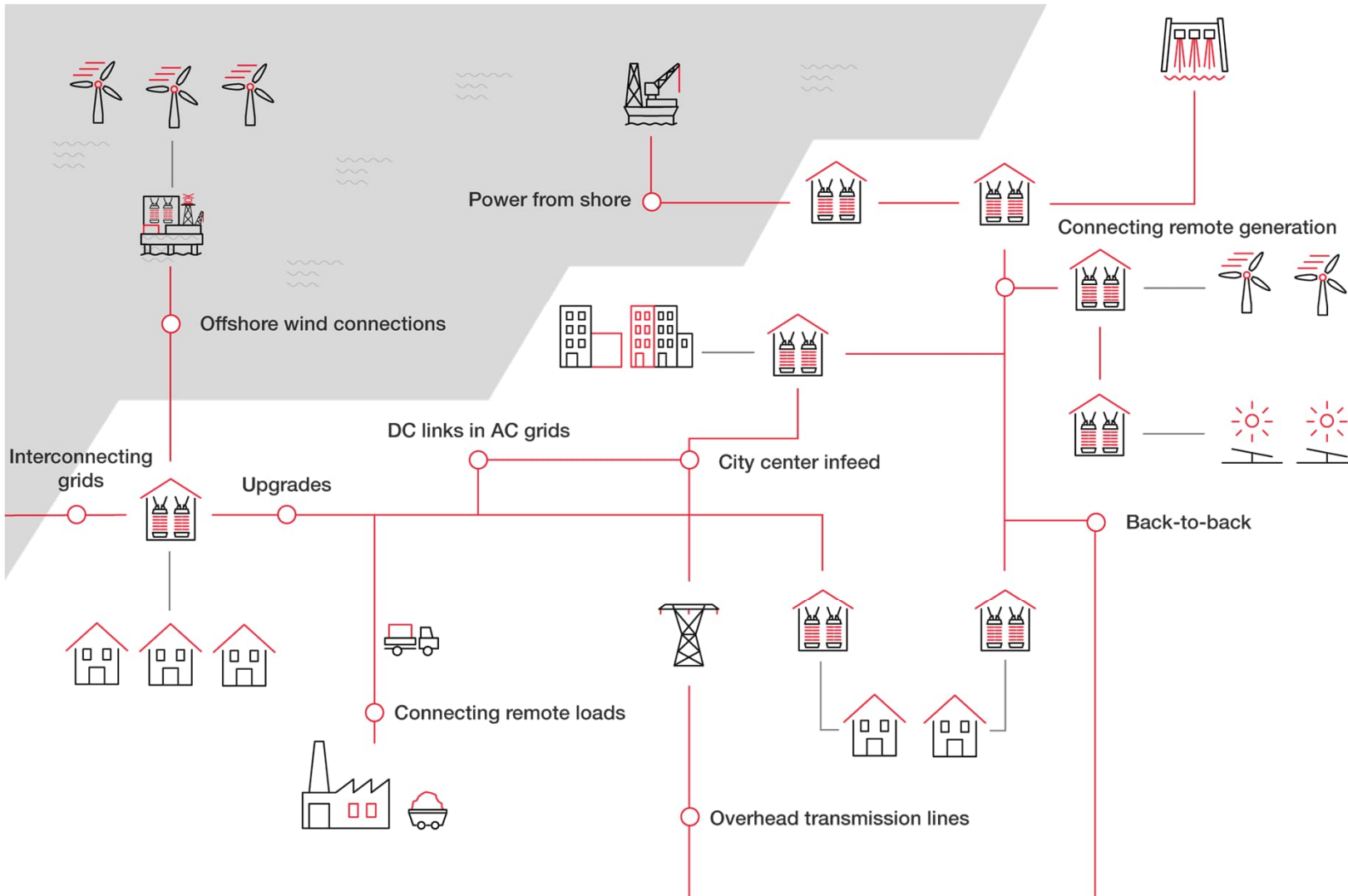

Connecting remote generation



Interconnecting grids



Offshore wind connections



Power from shore



DC links in AC grids



City center infeed



Connecting remote loads



Upgrades / life cycle services

# Offshore Wind – what's cooking?

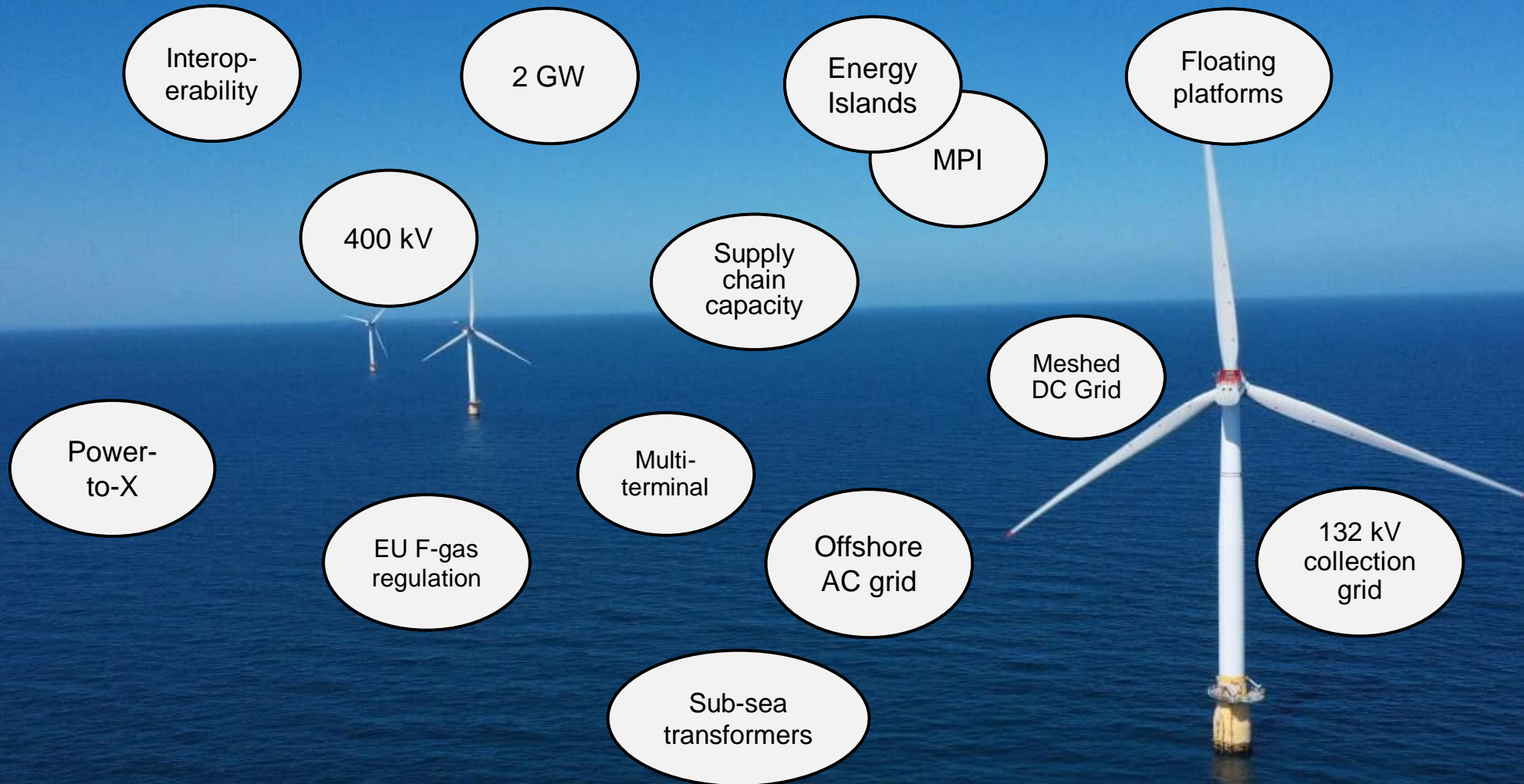

## Radial Connections

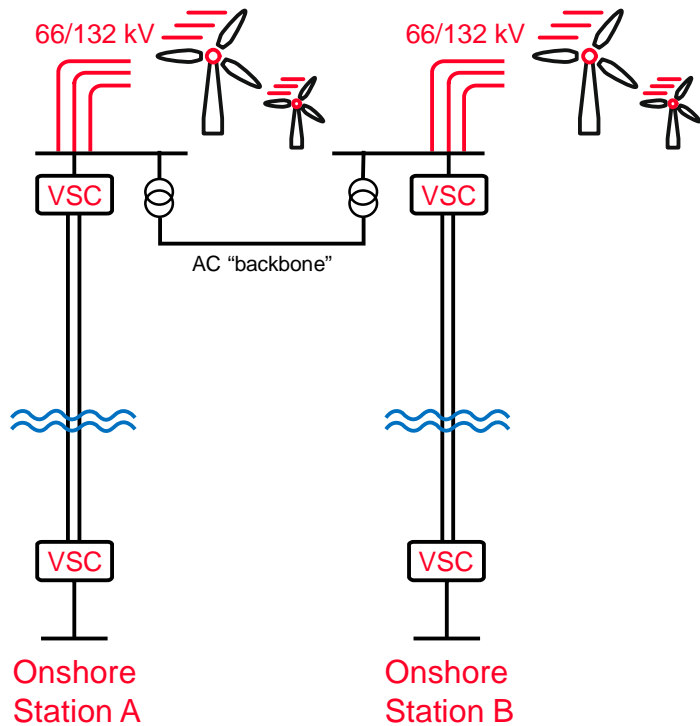

Cascading trips / AC Chopper  
Resonances / Harmonic Filters  
Converter Interaction / V/f control coordination

## Multi-Purpose Interconnections

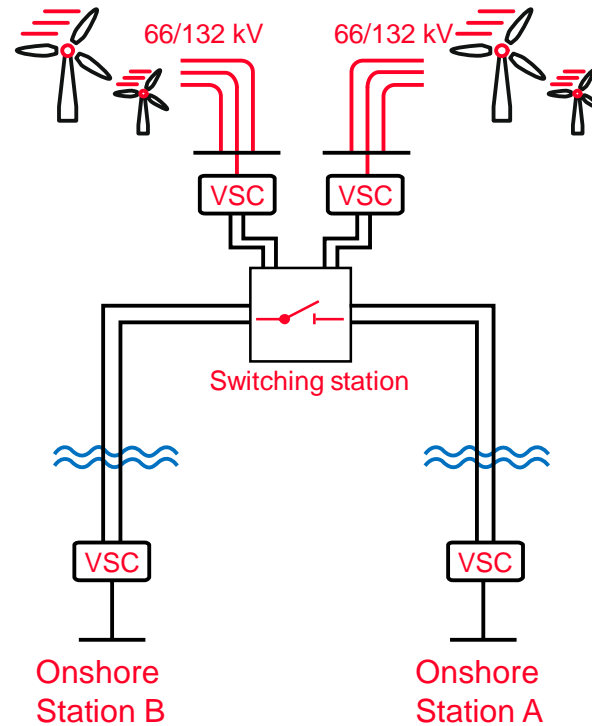

DC Circuit Breaker  
Interoperability  
Control mode coordination

## Meshed DC Grid

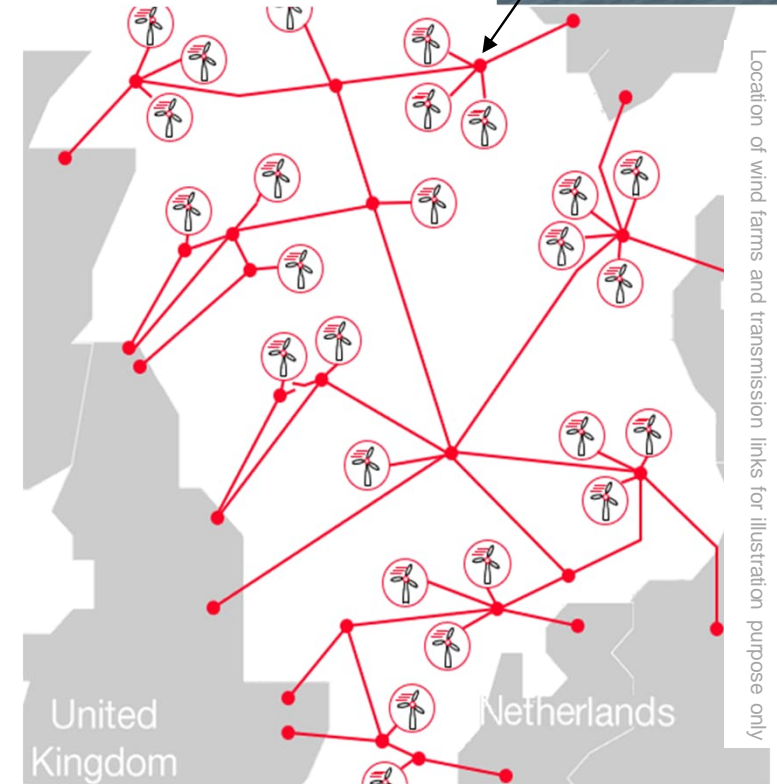

Expandability  
Power flow controllability  
Regulatory challenges

**HITACHI**  
Inspire the Next 